

MONTAJ KILAVUZU

adedto
Mobilya Çözüm

OLTU ÇALIŞMA MAŞASI

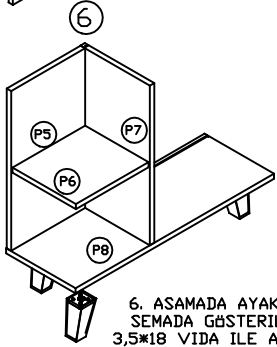
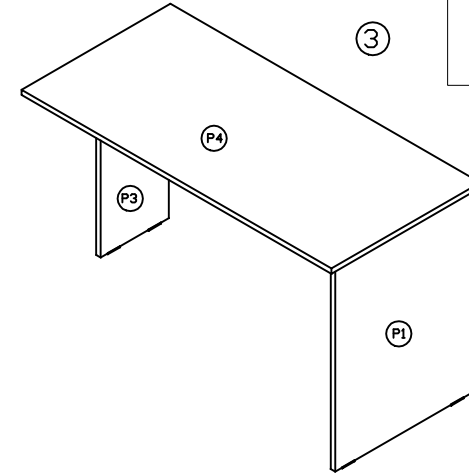
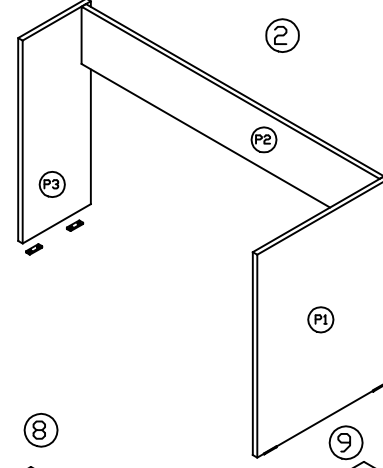
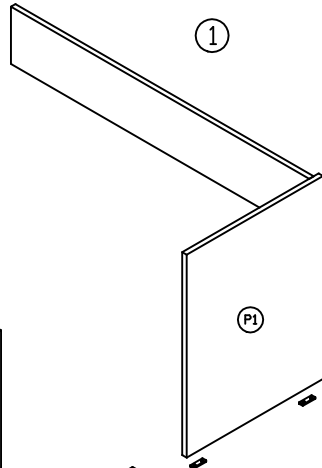
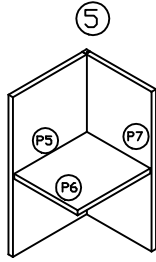
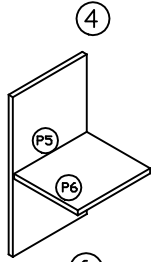
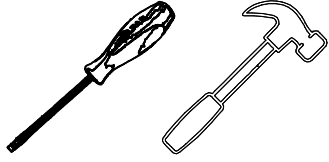

6. ASAMADA AYAK İSKELETİ
SEMADA GÖSTERİLDİĞİ GİBİ
3,5*18 VIDA İLE ALT TABLAYA
MONTE EDİNİZ. DAHA SONRA
AYAK GÖVDEYİ AYAK İSKELETE
GECİRİNİZ.

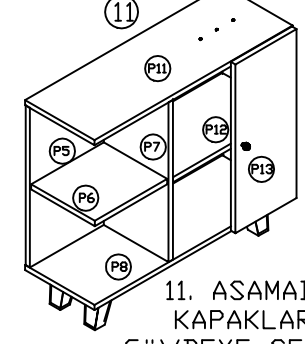
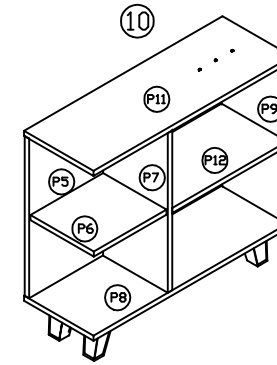
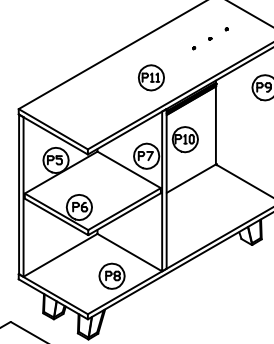
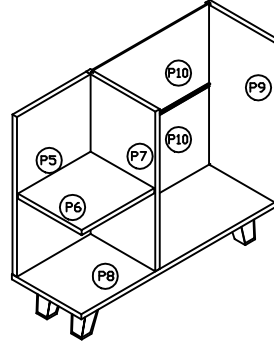
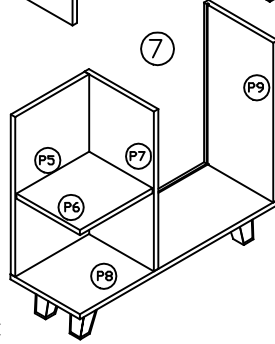

11. ASAMADA
KAPAKLARI
GÖVDEYE SEMADA
GÖSTERİLDİĞİ GİBİ
MONTE EDİNİZ

KONİK AYAK BAĞLANTI DETAYI

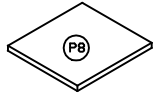

AYAK
İSKELET



AYAK
GÖVDE

12

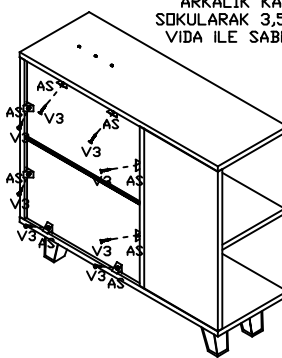

12. ASAMADA KİTAPLIK
MODÜLÜNÜN TERAZİSİ
SAGLANDIKTAN SONRA
UYGUN YERLERE ARKALIK
SABİTLEYİCİNİN TIRNAGI
ARKALIK KANALINA
SOKULARAK 3,5*25 (V3)
VIDA İLE SABİTLEYİNİZ.

13

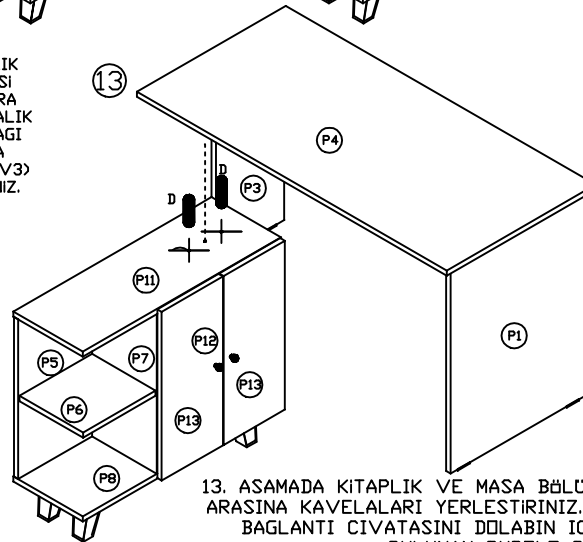

13. ASAMADA KİTAPLIK VE MASA BÖLÜMÜNÜ ÜST TABLALAR ÜZERİNDEKİ DELİKLER
ARASINA KAVELALARI YERLEŞTİRİNİZ. İKİ KAVELA ARASINDAKİ DELİKTEN (CV1)
BAĞLANTI CIVATASINI DOLABIN İCİNDEN MASA ÜST TABLASININ ALTINDA
BULUNAN DUBELE DENK GETİREREK SIKINIZ.

14

